



EHA05-(5-20)

User Manual

RECHARGEABLE LITHIUM ION BATTERY SYSTEM

Version: 2023 V1



Contents

About this document.....	01
1.Safety precaution.....	02
1.1 general safety.....	02
1.2 Safety Disclaimer.....	02
1.3 Personnel Requirements.....	03
1.4 Electrical Safety.....	04
1.5 Battery Safety.....	06
1.6 Storage Requirements.....	10
1.7 Transprotation Requirements.....	11
1.8 Installation Environment Requirements.....	12
1.9 Label Description.....	14
2.Product Introduction.....	15
2.1 Product Overview.....	15
2.2 Product Apperance.....	17
2.3 Nameplate.....	18
2.4 Dimension.....	19
3. System Installation	20
3.1 Checking Before Installation.....	20
3.2 Preparing Tools and Instruments.....	21
3.3 Check the Installation Position	22
3.4 Moving the Equipment.....	23
3.5 nstalling the Battery System.....	23
4. Electrical Connection	30
4.1 Safety Precaution.....	30
4.2 Electrical Connection.....	30
4.3 Connecting the PE cable.....	31
4.4 Connecting the Communication Cable.....	33
4.5 Connecting the Power Cable.....	34
4.6 Verifying the Installation	36
5. System Operation.....	37
5.1 Battery System ON and OFF	37
5.2 Indicator Status	37
5.3 Battery Commissioning	38

Contents

5.3.1 Brief Introduction	38
5.3.2 Download and Install APP.....	38
5.3.3 Account Registration.....	39
5.3.4 Password Recovery.....	40
5.3.5 Creat Plant.....	41
5.3.6 Collector Network.....	43
5.3.7 Plant Management.....	47
6. System Maintenance.....	48
6.1 Power OFF the Battery System.....	48
6.2 Routing Maintenance.....	48
6.3 Troubleshoot.....	49
6.4 Battery Storage and Recharge.....	50
7.Parameters.....	55

About This Document

Purpose





This document describes the EHA05 battery (also referred to as product, equipment or energy storage) in terms of its overview, application scenarios, installation and commissioning, system maintenance, and technical specifications. The EHA05 battery consists of a EHA0P power control unit and EHA05 battery modules.

Target Audience

This document is intended for:

- Sales engineers
- System engineers
- Technical support engineers
- End users

Symbol Definition

Stmbol	Description
	Indicates a hazard with a high level of risk which, if not avoided, will result in death or serious injury.
	Indicates a hazard with a medium level of risk which, if not avoided, could result in death or serious injury.
	Indicates a hazard with a low level of risk which, if not avoided, could result in minor or moderate injury.
	Indicates warning information about device or environment security which, if not avoided, could result in equipment damage, data loss, performance deterioration, or unanticipated results. NOTICE is used to address practices not related to personal injury.

1 Safety Precaution

Please strictly follow these safety instructions in the user manual during the operation.

General Disclaimer

NOTICE

The products are designed and tested strictly to comply with related safety rules. Read and follow all the safety instructions and cautions before any operations. Improper operation might cause personal injury or property damage as the products are electrical equipment.

1.1 General Safety

NOTICE

The information in this user manual is subject to change due to product updates or other reasons. This guide cannot replace the product labels or the safety precautions in the user manual unless otherwise specified. All descriptions in the manual are for guidance only. Before installations, read through the quick installation guide. For additional information, please see the user manual. All installations should be performed by trained and knowledgeable technicians who are familiar with local standards and safety regulations. Check the deliverables for correct model, complete contents, and intact appearance. Contact after sales service if any damage is found or any component is missing. Use insulating tools and wear personal protective equipment (PPE) when operating the equipment to ensure personal safety. Wear anti-static gloves, cloths, and wrist strips when touching electron devices to protect the equipment from damage. Strictly follow the installation, operation, and configuration instructions in this guide and relative user manual. The manufacturer shall not be liable for equipment damage or personal injury if you do not follow the instructions. For more warranty details, please visit: <https://www.leaptonpv.com>.

1.2 Safety Disclaimer

DANGER

- The battery system is a high voltage system. High voltage exists when the equipment is running. Please keep Power Off before any operations to avoid danger. Strictly follow all safety precautions outlined in this manual and safety labels on the equipment during the operation.
- The inverter used with the battery shall be approved by the battery manufacturer. The approved list of batteries and the matched inverter can be obtained through the official website.
- Do not disassemble, modify, or replace any part of the battery or the power control unit without official authorization from the manufacturer. Otherwise, it will cause electrical shock or damages to the equipment, which shall not be borne by the manufacturer. Do

not hit, pull, drag, squeeze or step on the equipment or put the battery into fire. Otherwise, the battery will be exploded.

- Do not place the battery in a high temperature environment. Make sure that there is no heat source near the battery and no direct sunlight. When the ambient temperature exceeds 60 C. it will cause a fire.
- Do not use the battery or the power control unit if it is defective, broken, or damaged. The damaged battery may leak electrolyte.
- To protect the battery pack and its components from damage during transportation, please ensure that the transportation personnel are professionally trained. All operations during the transportation have to be recorded. The equipment shall be kept in balance, thus avoiding falling down.
- The battery equipment is heavy. Please equip the corresponding personnel according to its weight, so that the equipment does not exceed the weight range of the human body can carry, and smash the personnel.
- Contact after-sale service immediately if the battery is not able to be started. Otherwise, the battery might be damaged permanently.
- Do not move the battery system if it is connected with external battery modules. Contact after-sale service if the battery shall be replaced or added.

CAUTION

- Protect the battery system from damage during transportation and storage.
- The transportation must be carried out by trained professionals. All operations during the process have to be recorded.
- Keep the equipment stable to avoid dumping, which can result in equipment damage and personal injuries.
- Place the cables at least 30mm away from the heating components or heat sources, otherwise the insulation layer of the cables may be aging or broken due to high temperature.
- Tie the cables of the same type together, and place cables of different types at least 30mm apart. Do not place the cables entangled or crossed.

1.3 Personnel Requirements

- Personnel who plan to install or maintain Leapton equipment must receive thorough training, understand all necessary safety precautions, and be able to correctly perform all operations.
- Only qualified professionals or trained personnel are allowed to install, operate, and maintain the equipment.

- Only qualified professionals are allowed to remove safety facilities and inspect the equipment.
 - Personnel who will operate the equipment, including operators, trained personnel, and professionals, should possess the local national required qualifications in special operations such as high-voltage operations, working at heights, and operations of special equipment.
 - Only professionals or authorized personnel are allowed to replace the equipment or components (including software).
-

NOTICE

- Professionals: personnel who are trained or experienced in equipment operations and are clear of the sources and degree of various potential hazards in equipment installation, operation, and maintenance.
 - Trained personnel: personnel who are technically trained, have required experience, are aware of possible hazards on themselves in certain operations, and are able to take protective measures to minimize the hazards on themselves and other people.
 - Operators: operation personnel who may come in contact with the equipment, except trained personnel and professionals.
-

1.4 Electrical Safety

Grounding Requirements

- For the equipment that needs to be grounded, install the protective earthing (PE) cable first when installing the equipment and remove the PE cable last when removing the equipment.
- Do not damage the ground conductor.
- Do not operate the equipment in the absence of a properly installed ground conductor.
- Ensure that the equipment is connected permanently to the protective round. Before operating the equipment, check the electrical connection to ensure that it is securely grounded.

General Requirements

DANGER

Before connecting cables, ensure that the equipment is intact. Otherwise, electric shocks or fire may occur.

- Ensure that all electrical connections comply with local electrical standards.
- Obtain approval from the local electric utility company before using the equipment in grid-tied mode.

- Ensure that the cables you prepared meet local regulations.
- Use dedicated insulated tools when performing high-voltage operations.

DC Operation

DANGER

Do not connect or disconnect power cables with power-on. Transient contact between the core of the power cable and the conductor will generate electric arcs or sparks, which may cause fire or personal injury.

- Before connecting cables, switch off the disconnecter on the upstream equipment to cut off the power supply if people may contact energized components.
- Before connecting a power cable, check that the label on the power cable is correct.
- If the equipment has multiple inputs, disconnect all the inputs before operating the equipment.

Cable Requirements

- When routing cables, ensure that a distance of at least 30 mm exists between the cables and heat-generating components or areas. This prevents damage to the insulation layer of the cables.
- Bind cables of the same type together. When routing cables of different types, ensure that they are at least 30 mm away from each other.
- Ensure that the cables used in a grid-tied PV power system are properly connected and insulated and meet specifications.
- The positions where cables are routed through pipes or holes must be protected to prevent the cables from being damaged by sharp edges or burrs.
- When the temperature is low, violent impact or vibration may damage the plastic cable sheathing. To ensure safety, comply with the following requirements:
 - Cables can be laid or installed only when the temperature is higher than 0°C. Handle cables with caution, especially at a low temperature.
 - Cables stored at subzero temperatures must be stored at room temperature for at least 24 hours before they are laid out.

ESD

NOTICE

The static electricity generated by human bodies may damage the electrostaticsensitive components on boards, for example, the large-scale integrated (LSI) circuits.

- Wear ESD gloves when handling the equipment. Do not wear clothes prone to static electricity

1.5 Battery Safety

Declaration

The Company shall not be liable for equipment functional abnormality, component damage, personal safety accident, property loss, or other damage caused by the following reasons:

- The batteries are not charged as required during storage, resulting in capacity loss or irreversible damage to the batteries.
- A battery is damaged, falls, or leaks due to improper operations or incorrect connection.
- After being installed and connected to the system, the batteries are not powered on in time, which causes damage to the batteries due to overdischarge.
- Battery running parameters are incorrectly set.
- The customer or a third party uses the batteries beyond the scenarios specified by the Company. For example, connect extra loads, or use with other batteries, including but not limited to batteries of other brands or batteries of different rated capacities.
- Damage is caused to batteries because the battery operating environment or external power parameters do not meet environment requirements. The actual operating temperature of batteries is too high or too low, or the power grid is unstable and experiences outages frequently.
- Batteries are frequently overdischarged due to improper maintenance, capacity is incorrectly expanded, or the batteries have not been fully charged for a long time.
- Batteries are not maintained based on the operation guide, such as failure to check battery terminals regularly.
- Batteries are stolen.
- The warranty period of batteries has expired.

Basic Requirements

DANGER

- Do not expose batteries at high temperatures or around heat-generating sources, such as sunlight, fire sources, transformers, and heaters. The battery may cause a fire if overheated.
- To avoid leakage, overheating, or fire, do not disassemble, alter, or damage batteries. For example, do not insert foreign objects into batteries or place batteries in water or other liquids.
- The fire hazard of the lithium-ion/sodium-ion battery energy storage system is high. Consider the following safety risks before handling batteries:

- (a) Battery electrolyte is combustible, toxic, and volatile.
 - (b) Battery thermal runaway can generate flammable gas and harmful gas such as CO and HF.
 - (c) The concentration of flammable gas generated from battery thermal runaway may cause deflagration and explosion.
-

- The batteries must be stored separately inside the packaging. Do not store batteries together with other materials or in the open air.
- Do not stack batteries too high.
- Do not use batteries beyond the warranty period.
- Do not remove the battery packaging before use. Batteries should be charged during storage by professionals as required. Put batteries back to their packaging after charge during storage.
- Move batteries in the correct direction. Do not place a battery upside down or tilt it.
- Protect batteries from impact.
- Do not perform welding or grinding work around batteries to prevent fire caused by electric sparks or arcs.
- Use batteries within the temperature range specified in this manual.
- Do not use damaged batteries (such as damage caused when a battery is dropped, bumped, or dented on the enclosure). Damaged batteries may release flammable gases.
- Do not store damaged batteries near undamaged products.
- Do not place damaged batteries in close proximity to flammable materials.
- Do not approach the damaged batteries unless you are a professional.
- Monitor damaged batteries during storage for signs of smoke, flame, electrolyte leakage, or heat.

Personal Safety

- Wear proper personal protective equipment (PPE) during operation. If there is a probability of personal injury or equipment damage, immediately stop the operations, report the case to the supervisor, and take feasible protective measures.
- Use tools correctly to avoid hurting people or damaging the equipment.
- Do not touch the energized equipment, as the enclosure is hot.
- To ensure personal safety and normal use of the equipment, the equipment must be reliably grounded before use.

- When a battery is faulty, the temperature may exceed the burn threshold of the touchable surface. Therefore, avoid touching the battery.
- Do not disassemble or damage the battery. The released electrolyte is harmful to your skin and eyes. Avoid contact with the electrolyte.
- Do not place irrelevant objects on the top of the equipment or insert them into any position of the equipment.
- Do not place inflammables around the equipment.
- To prevent explosions and body injury, do not place batteries in a fire.
- Do not place the battery module in water or other liquids.
- Do not short-circuit wiring terminals of batteries. Short circuits can cause a fire.
- Batteries may cause electric shocks and high short-circuit currents. When using the battery, pay attention to the following points:
 - (a) Remove any metal objects from yourself, such as watches and rings.
 - (b) Use tools with insulated handles.
 - (c) Wear rubber gloves and boots.
 - (d) Do not place tools or metal parts on top of batteries.
 - (e) Before connecting or disconnecting battery terminals, disconnect the charging power supply.
 - (f) Check whether batteries are accidentally grounded. If it is accidentally grounded, remove the power supply from the ground. Touching any part of a grounded battery can cause an electric shock. If these grounding points are removed during installation and maintenance, the possibility of electric shocks can be reduced.
- Do not use water to clean electrical components inside or outside of a cabinet.
- Do not stand on, lean on, or sit on the top of the equipment.
- Do not damage the modules of the equipment.

Battery Installation Requirements

- Before installing batteries, check whether the packaging is intact. Do not use batteries with damaged packaging.
- During installation, ensure that the positive and negative electrodes of a battery are not short-circuited.
- During installation, ensure that the screws are tightened properly using a torque wrench and check them regularly.
- After installing the equipment, remove idle packing materials such as cartons, foam, plastics, and cable ties from the equipment area.

Hazardous and Toxicity Class

DANGER

- Hazard: It may cause heat generation or electrolyte leakage if battery terminals contact with other metals. Electrolyte is flammable. In case of electrolyte leakage, move the battery from fire immediately.
 - Toxicity: Vapor generated from burning batteries, may make eyes, skin, and throat irritate.
-

Battery Emergency Measures

DANGER

If the battery module leaks electrolyte, avoid contact with the leaking liquid or gas. The electrolyte is corrosive. It will cause skin irritation or chemical burn to the operator. Any one contacts the leaked substance accidentally has to do as following:

- Breath in the leaked substance: Evacuate from the polluted area, and seek immediate medical assistance.
 - Eye contact: Rinse your eyes for at least 15 minutes with clean water and seek immediate medical assistance.
 - Skin contact: Thoroughly wash the touch area with soap and clean water, and seek immediate medical assistance.
 - Ingestion: Induce vomiting, and seek immediate medical assistance.
-

Fire Emergency Measures

DANGER

- The battery may explode when the ambient temperature exceeds 150°C. Poisonous and hazardous gas may be released if the battery is on fire.
 - In the event of a fire, please make sure that the carbon dioxide extinguisher or Novac1230 or FM-200 is nearby.
 - The fire cannot be put out by water or ABC dry powder extinguisher. Firefighters are required to wear full protective clothing and self-contained breathing apparatus.
-

Flood Emergency Measures

DANGER

- Power off the system if it is safe to do so.
 - If any part of the batteries is submerged in water, do not touch the batteries to avoid electric shock.
 - Do not use batteries that have been soaked in water. Contact a battery recycling company for disposal.
-

Dropped Battery Emergency Measures

DANGER

- If a battery pack is dropped or violently impacted during installation, internal damage may occur. Do not use such battery packs; otherwise, safety risks such as cell leakage and electric shock may arise.
- If a dropped battery has obvious damage or abnormal odor, smoke, or fire occurs, evacuate the personnel immediately, call emergency services, and contact the professionals. The professionals can use fire extinguishing facilities to extinguish the fire under safety protection.
- If a dropped battery has no obvious deformation or damage and no abnormal odor, smoke, or fire occurs, contact the professionals to transfer the battery to an open and safe place, or contact a recycling company for disposal.

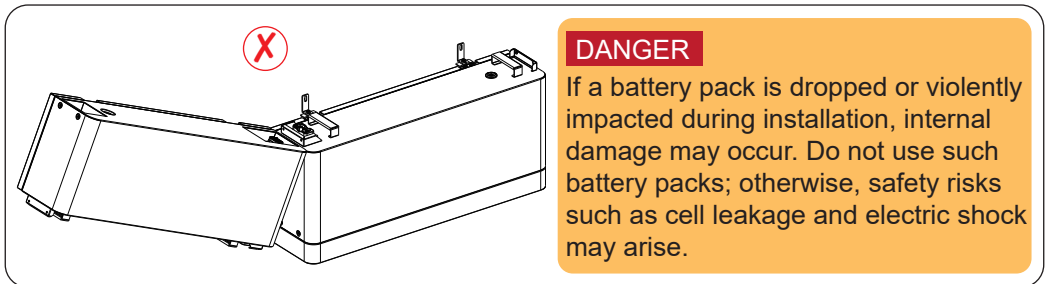

Battery Recycling

- Dispose of used batteries in accordance with local laws and regulations. Do not dispose of batteries as household waste.
- If the batteries leak or are damaged, contact technical support or a battery recycling company for disposal.
- If the batteries are out of service life, contact a battery recycling company for disposal.
- Do not expose batteries to high temperatures or direct sunlight.
- Do not expose batteries to high humidity or corrosive environments.

1.6 Storage Requirements

NOTE:

- Record storage data such as temperature, humidity, and storage environment in compliance with the storage requirements in this manual.
- Do not store batteries for extended periods. Storing lithium batteries for extended periods may cause capacity loss. Generally, the irreversible capacity loss is 3% to 10% after lithium batteries are stored at the recommended storage temperature range for 12months.

- The storage environment must comply with local regulations and standards.
- If a battery has been stored for longer than the allowed period, it must be checked and tested by professionals before use.
- Place batteries according to the signs on the packing case during storage. Do not put batteries upside down or sidelong.
- Stack battery packing cases in compliance with the stacking requirements on the external package.
- Handle batteries with caution to avoid damage.

The storage environment requirements are as follows:

- Ambient temperature: -10–55°C; recommended storage temperature: 20–30°C
- Relative humidity: 5% to 80%.
- The batteries must be stored in a clean, dry, and well-ventilated place and be protected from dust and water vapor corrosion. The batteries must be protected against rain and water.
- Relative humidity: 5% to 80%
- Keep batteries away from direct sunlight.

1.7 Transportation Requirements

NOTICE

The product passes the certifications of the UN38.3 (UN38.3: Section 38.3 of the sixth Revised Edition of the Recommendations on the Transport of Dangerous Goods: Manual of Tests and Criteria) and SN/T 0370.2-2009 (Part 2: Performance Test of the Rules for the Inspection of Packaging for Exporting Dangerous Goods). This product belongs to Class 9 dangerous goods.

Loading and unloading

Load and unload the batteries in compliance with local laws, regulations, and industry standards. Reckless handling may cause short circuits or damage to batteries in the container, which may result in battery leakage, rupture, explosion, or fire.

Before transportation

- Check that the batteries are intact and there is no obvious odor, smoke, or fire. Otherwise, the batteries cannot be transported.

NOTE:

The product can be delivered to the site directly and transported by land and water. The packing case must be secured for transportation. Handle the product with care during loading, unloading, and transportation with moisture-proof measures in place. The actual capacity may vary depending on the environment conditions, such as temperature, transportation conditions, and storage conditions.

During transportation:

- The batteries cannot be transported by rail or air.
- Maritime transport must comply with the International Maritime Dangerous Goods Code (IMDG Code).
- Road transport must comply with the International Carriage of Dangerous Goods by Road (ADR) or JT T617.
- Comply with the requirements of the transportation regulatory authorities in the countries of departure, route, and destination.

Comply with the international regulations on the transport of dangerous goods and the requirements of the transport regulatory authorities of the respective countries.

Protect the packing case with the product from the following situations:

- Being dampened by rains, snows, or falling into water.
- Falling or mechanical impact.
- Being upside-down or tilted.

NOTE:

If any of the preceding exceptions occurs, take the emergency measures.

1.8 Installation Environment Requirements

- The installation and use environment must meet relevant international, national, and local standards for lithium batteries, and are in accordance with the local laws and regulations.
- Ensure that the battery is not accessible to children and away from daily working or living areas, including but not limited to the following areas: studio, bedroom, lounge, living room, music room, kitchen, study, game room, home theater, sunroom, toilet, bathroom, laundry, and attic.
- When installing the battery in a garage, keep it away from the drive way. It is recommended that the battery be mounted on the wall higher than the bumper to prevent collision.
- When installing the battery in a basement, keep good ventilation. Do not place flammable or explosive materials around the battery. It is recommended that the battery be mounted on the wall to avoid contact with water.
- Install the battery in a dry and well-ventilated environment. Secure the battery on a solid and flat surface.
- Install the battery in a sheltered place or install an awning over it to avoid direct sunlight or rain.
- Install the battery in a clean environment that is free from sources of strong infrared radiation, organic solvents, and corrosive gases.





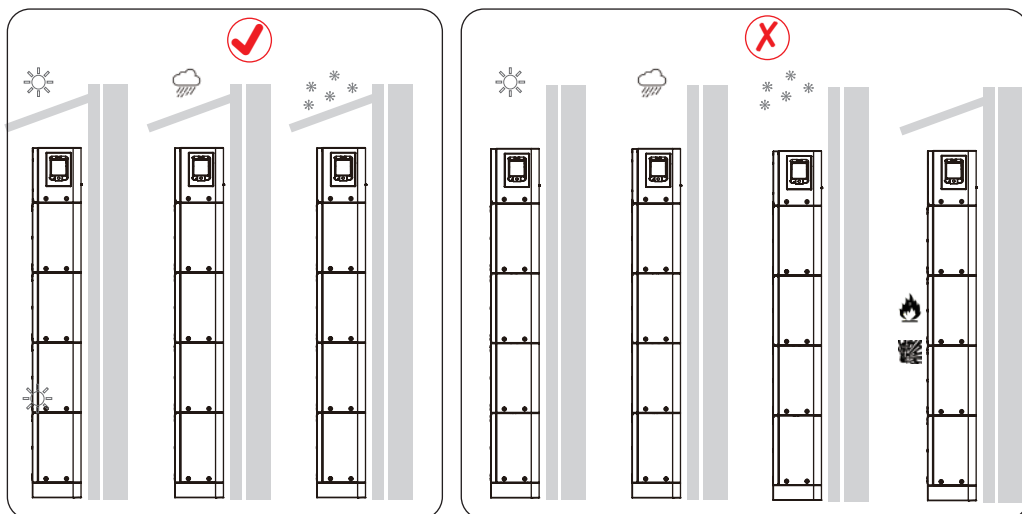

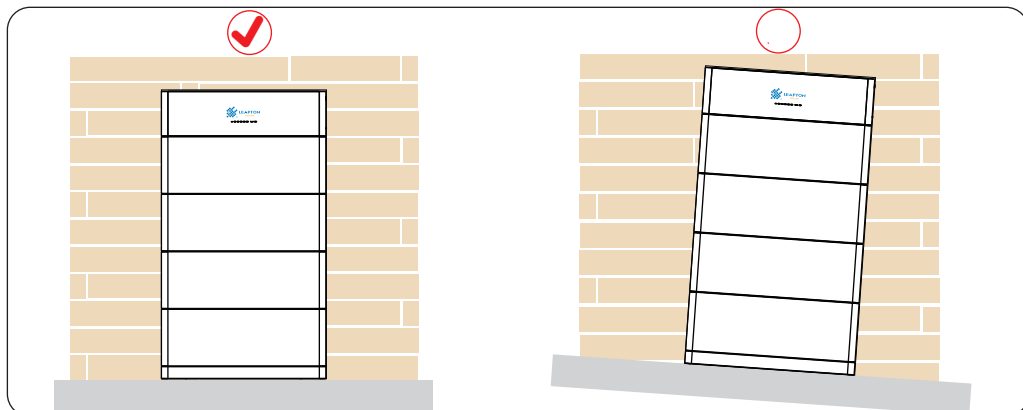





- For areas prone to natural disasters such as floods, debris flows, earthquakes, and typhoons/hurricanes, take corresponding precautions for installation.
- Keep the battery away from fire sources. Do not place any flammable or explosive materials around the battery.
- Keep the battery away from water sources such as taps, sewer pipes, and sprinklers to prevent water seepage.
- Do not install the battery in a position where it is easy to touch as the temperature of the chassis and heat sink is high when the battery is running.
- To prevent fire due to high temperature, ensure that the vents and the cooling system are not blocked when the battery is running.
- Do not expose the battery to flammable or explosive gas or smoke. Do not perform any operation on the battery in such environments.
- Do not install the battery on a moving object, such as ship, train, or car.
- In backup power scenarios, do not use the battery for the following situations:
 - a. Medical devices substantially important to human life.
 - b. Control equipment such as trains and elevators which may cause personal injury.
 - c. Computer systems of social and public importance.
 - d. Locations near medical devices.
 - e. Other devices similar to those described above.
- Do not install the battery outdoors in salt-affected areas because it may corrode. A salt-affected area refers to the region within 500 meters from the coast or prone to sea breeze. The regions prone to sea breeze vary with weather conditions (such as typhoons and monsoons) or terrains (such as dams and hills).

Figure:Installation environment





1.9 Label Description

	Potential risks exist. Wear proper PPE before any operations.		Do not place at the children and pet touchable area.
	HIGH VOLTAGE HAZARD. High voltage exists during the equipment's running. Ensure the equipment is powered off before any operations.		Do not reverse connection the positive and negative.
	Operate the equipment properly to avoid explosion danger.		Label for Waste Electrical and Electronic Equipment (WEEE) Directive (2012/19/EU)
	Batteries contain flammable materials, beware of fire.		Recycle label
	Read the product and operation manual before operating the battery system		CE Marking
	Read the product and operation manual before operating the battery system		The certificate label for Safety by TÜV NORD

2 Product Introduction

2.1 Product Overview

Intended usage

The battery system, which consists of a power control unit (PCU for short) and battery modules, can store and release the electric energy according to the requirements of the solar energy storage system. The input and output ports of the energy storage system are high voltage direct current ports.

Model

- Model of the Product(5kwh~20kWh):

5kWh Battery System: EH-A05-102/102

10kWh Battery System:EH-A05-102/204

15kWh Battery System:EH-A05-102/307

20kWh Battery System:EH-A05-102/409

Note:

EH:Product Code;

A05:The design code and power level is 5kWh;

102:The normal voltage of one battery module is 102V;

102 & 204 & 307 & 409:The normal voltage of the 5kWh, 10kWh, 15kWh and 20kWh battery system is 102V,204V,307V and 409V respectively.

- Model of the power control unit(PCU):

EHA0P

Note:

EH:Product Code;

A0P:The design code of PCU

- Model of the battery module :

EHA05

Note:

EH:Product Code;

A05:The design code and power level is 5kWh;

Usable energy description

The battery system supports capacity expansion. A maximum of five battery modules can be used to extend the usable energy of the battery system.

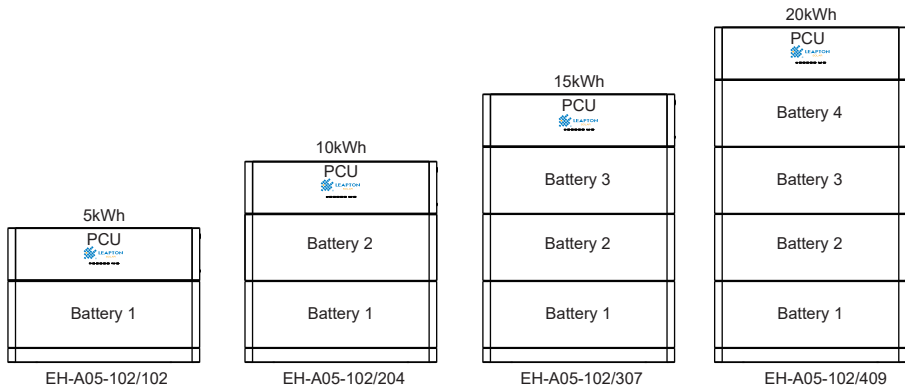

A max of 2 battery systems can be parallel connected in one energy storage system. Ensure that the usable energy of each battery system is the same.

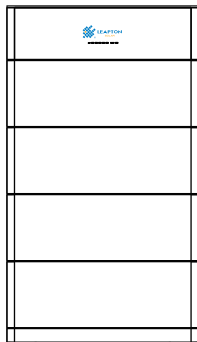

Battery system 1

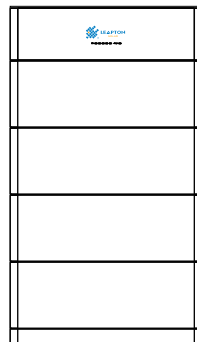

Battery system 2

Networking Application

The EHA05 battery system is applicable to the grid-tied systems of residential rooftop PV plants. Typically, a grid-tied system consists of PV strings, EHA05 batteries, an inverter, an AC switch, and a power distribution box (PDB).

2.2 Product Appearance

Battery System Appearance(20kWh)

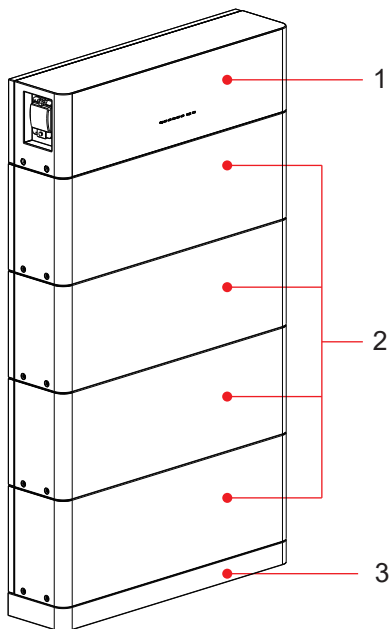

NOTICE

- Ensure that the PCU is installed above the battery modules. Do not install any battery modules above the PCU.
- This manual will show you the installation and electrical connection of 5 battery modules.

1. Power Control Unit
2. Battery
3. Base support

Battery Appearance

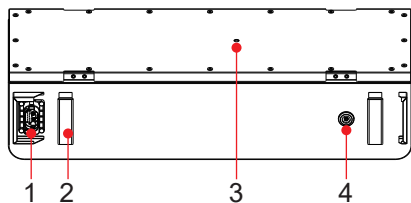

1. Retangular Connector
2. Battery Orientation
3. Lifting Handle
4. Ventilation Valve

Base Support Appearance

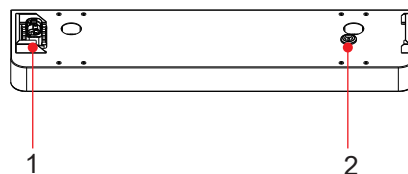

1. Retangular Connector
2. Battery Orientation
3. Lifting Handle

Power Control Unit Appearance

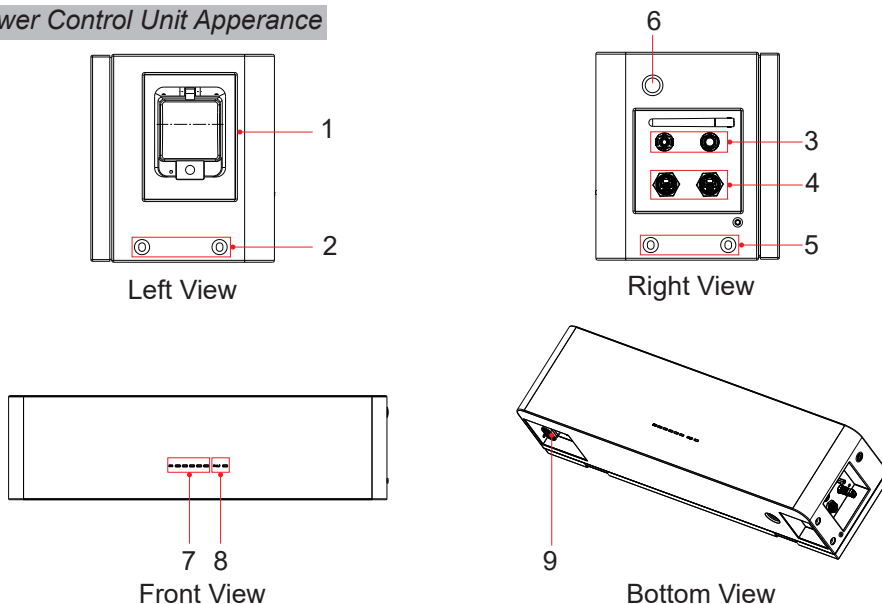

- | | | |
|---------------------------|---------------------------|--------------------------|
| 1. Circuit Breaker | 2. Left Battery Mounting | 3. DC Terminal |
| 4. Communication Terminal | 5. Right Battery Mounting | 6. Button Indicator |
| 7. SOC Indicator | 8. Fault Indicator | 9. Rectangular Connector |

2.3 Nameplate

Product Name: LFP Lithium Ion Energy Storage Battery System Capacity: 50Ah IP Rating: IP65 Recommend Charge Current: 25A Protect Class: I	
Model □IEH-A05-102/102 5.12kWh □IEH-A05-102/204 10.24kWh □IEH-A05-102/307 15.36kWh □IEH-A05-102/409 20.48kWh	Energy 102.4V 204.8V 307.2V 409.6V
Nominal Voltage IFP42/151/108/32S/151E/20+50/90 IFP42/151/108/32S/25E/20+50/90 IFP42/151/108/32S/35E/20+50/90 IFP42/151/108/32S/45E/20+50/90	
⚠ DANGER	
<ul style="list-style-type: none"> * Do not disconnect or disassemble by non-professional personnel. * Do not drop, deform, impact, cut or spear with a sharp object. * Do not place at a children or pet touchable area. * Do not cover or wrap the product case. * Do not sit or put heavy things on battery. * Do not touch the leaking liquid. * Do not immerse the battery in water. * Do not leave the battery nearby fire. * Avoid of direct sunlight. * Follow the product manual to make wiring connection. * If leaking, fire, wet, or damaged, switch off the breaker on DC side and stay away from battery. 	
<small> No.3 Sankui Avenue, Yuhai High Technology Industry Zone, Changshu City, Jiangsu Province, 215509P.R.China Suzhou Leapton Energy Co., LTD. www.leaptonpv.com </small>	

Nameplate of Battery System and PCU

IFP42/151/108/32S/IE/20+50/90	
Product Name: Rechargeable Li-Ion Battery Product Model: EHA05 Voltage Range: 91.2V~115.2V Rated Energy/Capacity: 5.12kWh/50Ah Nominal Voltage: 102.4V Charging Temperature Range: 0~50°C Discharging Temperature Range: -20~50°C IP Rating: IP65	
⚠ DANGER	
<ul style="list-style-type: none"> * Do not disconnect or disassemble by non-professional personnel. * Do not drop, deform, impact, cut or spear with a sharp object. * Do not place at a children or pet touchable area. * Do not cover or wrap the product case. * Do not sit or put heavy things on battery. * Do not touch the leaking liquid. * Do not immerse the battery in water. * Do not leave the battery nearby fire. * Avoid of direct sunlight. * Follow the product manual to make wiring connection. * If leaking, fire, wet or damaged, switch off the breaker on DC side and stay away from battery. 	
<small> No.3 Sankui Avenue, Yuhai High Technology Industry Zone, Changshu City, Jiangsu Province, 215509P.R.China Suzhou Leapton Energy Co., LTD. www.leaptonpv.com </small>	

Nameplate of Battery module

2.4 Dimension

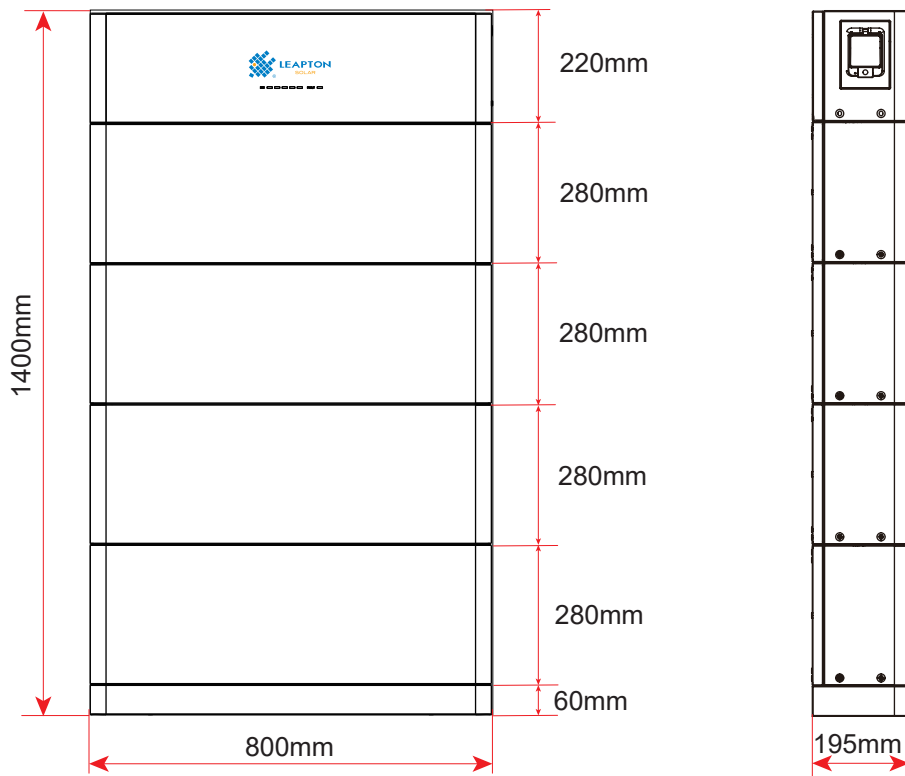

3 System Installation

3.1 Checking Before Installation

Check the Outer Packing

Check the following items before receiving the product.

1. Check the outer packing box for damage, such as holes, cracks, deformation, and other signs of equipment damage. Do not unpack the package and contact the supplier as soon as possible if any damage is found.
2. Check the product model. If the product model is not what you requested, do not unpack the product and contact the supplier.
3. Check the deliverables for correct model, complete contents, and intact appearance. Contact the supplier as soon as possible if any damage is found.

Check Deliverables

Deliverables(PCU & Base Support)

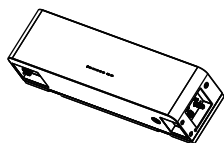

x1

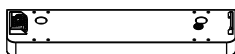

x1



x6(one for spare)



x2

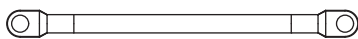

x1



x1



x1



x1

Deliverables(Battery)

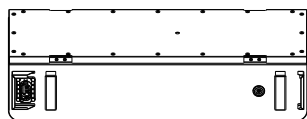

x1



x2



x2











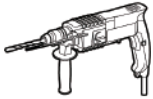
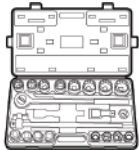

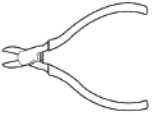
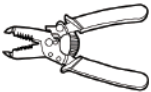
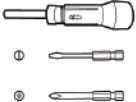



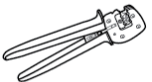

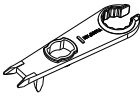



x10

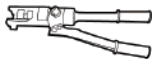

x2

3.2 Preparing Tools and Instruments

Type	Tools and Instruments		
Installation	 Hammer drill (with a drill bit of 8 mm)	 Torque socket wrench	 Torque wrench
	 Diagonal pliers	 Wire strippers	 Torque screwdriver
	 Rubber mallet	 Utility knife	 Cable cutter
	 Crimping tool(model: TE-T3100001001-000)	 Cord end terminal crimper	 Disassembly and Assembly Tool(Model: WETL,WE-PVTW)
	 Cable tie	 Vacuum cleaner	 Multimeter (DC voltage measurement range ≥ 600 V DC)

Type	Tools and Instruments		
Installation	 Marker	 Steel measuring tape	 Level
	 Hydraulic pliers	 Heat-shrink tubing	 Heat gun
Personal protective equipment (PPE)	 Safety gloves	 Safety goggles	 Dust mask
	 Safety boots	-	-

3.3 Check the Installation Position

Installation Angle Requirements

The battery can be floor-mounted. The installation angle requirement is as follows:

- Do not install the battery at forward tilted, back tilted, side tilted, horizontal, or upside down positions.

Installation Position Requirements

Install the battery on a solid brick-concrete structure or concrete wall or floor. If other types of walls and floors are used, they must be made of fire-retardant materials and meet the load-bearing requirements of the equipment.

Installation Space Requirements

During installation, ensure that there is no other devices (except related devices and awnings) or flammable or explosive materials around the batteries. Reserve adequate space for heat dissipation and safety isolation.

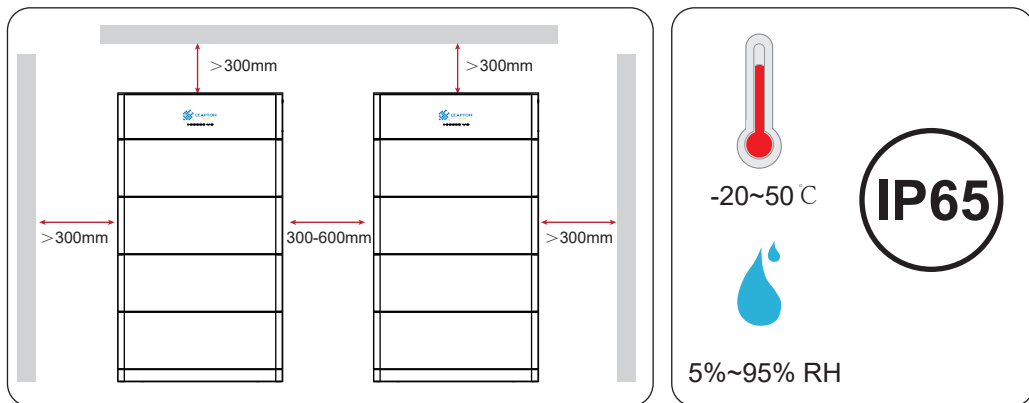

3.4 Moving the Equipment

⚠ CAUTION

- Operations such as transportation, turnover, installation and so on must meet the requirements of the laws and regulations of the country or region where it is located.
- Move the equipment to the site before installation. Follow the instructions below to avoid personal injury or equipment damage.
 1. Consider the weight of the equipment before moving it. Assign enough personnel to move the equipment to avoid personal injury.
 2. Wear safety gloves to avoid personal injury.
 3. Keep balance to avoid falling down when moving the equipment.

3.5 Installing the Battery System

Mounting Hole Dimensions

⚠ DANGER

Avoid drilling holes in the water pipes and cables buried in the wall.

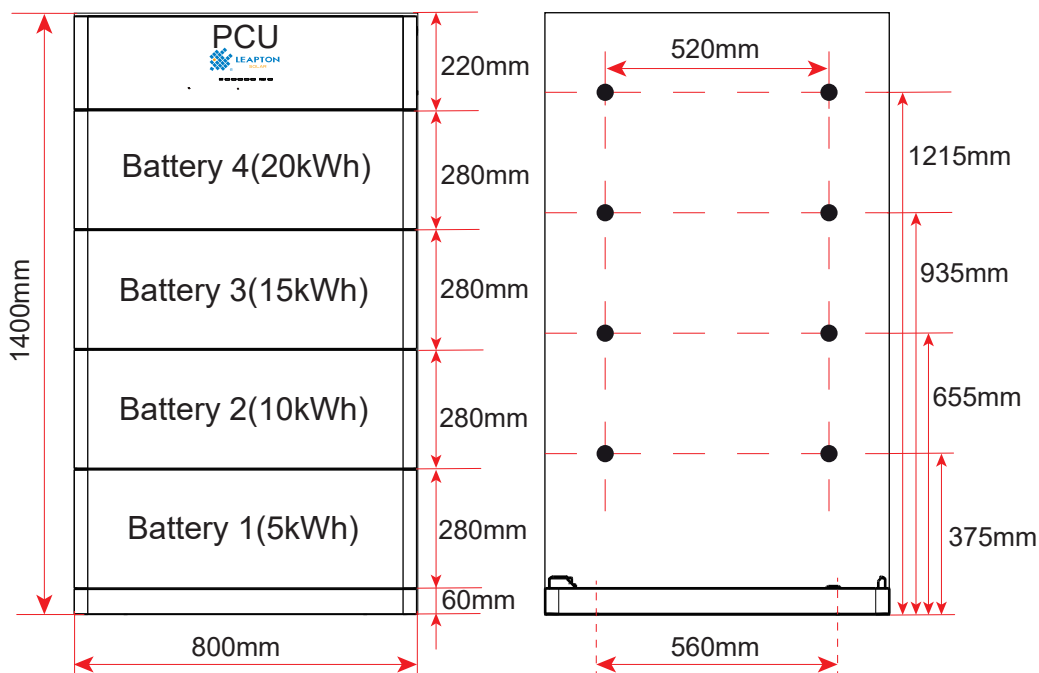

Drilling Holes and Installing the Base Support

- Step 1: Place the base support on the ground, Keep a distance of 35mm to 45mm between the support and the wall surface;
- Step 2: Ensure that the base support stands on the floor vertically.
- Step 3: Mark the mounting holes for the battery module ;
- Step 4: Drill holes using the hammer drill.
- Step 5: Secure the base support on the ground.Ensure the base support is installed in the correct direction.

1 Base Mounting Holes

Keep a distance of 35mm to 45mm between the support and the wall surface

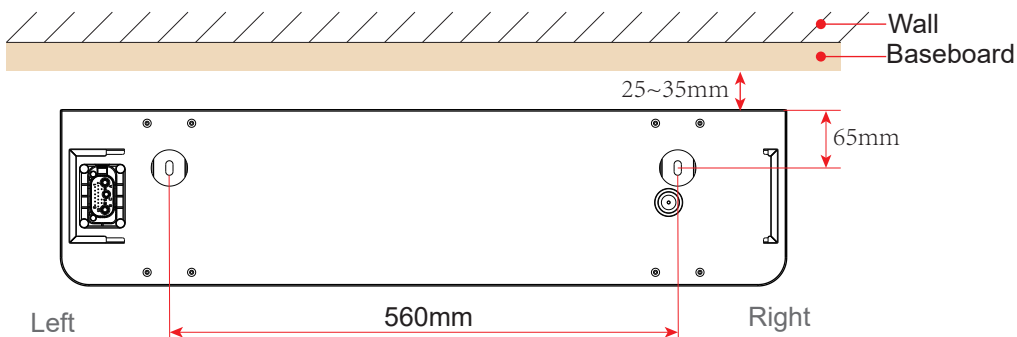

2

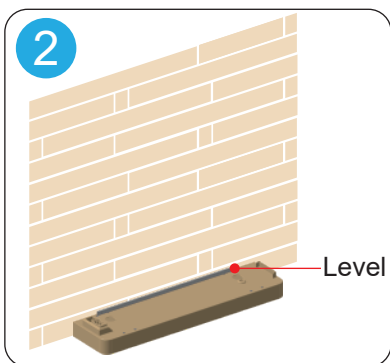

4

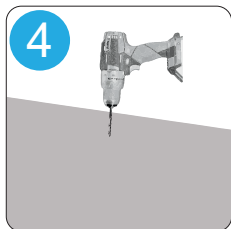

3 Pack Mounting Holes

3

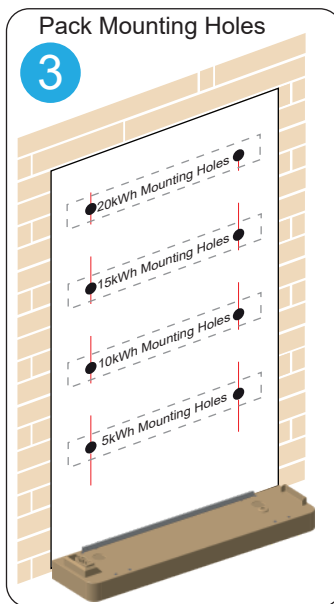

Requirements of Drill holes

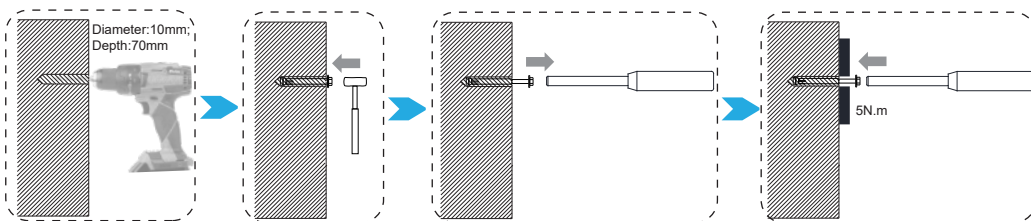

The M6x70 expansion bolts delivered with the battery are mainly used for solid concrete walls and concrete floors. If other types of walls and floors are used, ensure that the walls and floors meet the load-bearing requirements (one battery module weighs 55kg) and select the bolts by yourself.

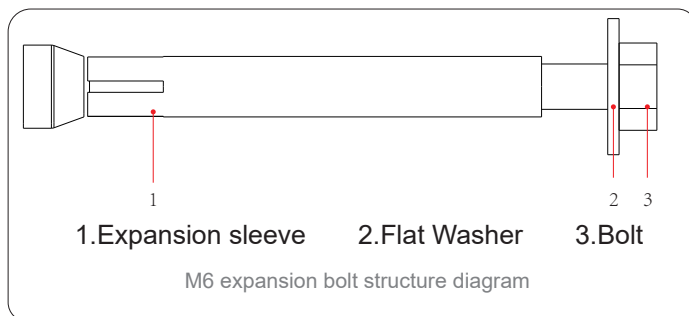

NOTICE

- To prevent dust inhalation or contact with eyes, wear safety goggles and an anti-dust mask when drilling holes.
- Wipe away any dust in or around the holes and measure the hole distances. If the holes are inaccurately positioned, drill holes again.
- Level the head of the expansion sleeve with the concrete wall or floor after removing the bolt and flat washer. Otherwise, the mounting kit will not be securely installed on the wall or ground.
- Secure the battery or base support with bolt and flat washer.

5 Secure the Base Support

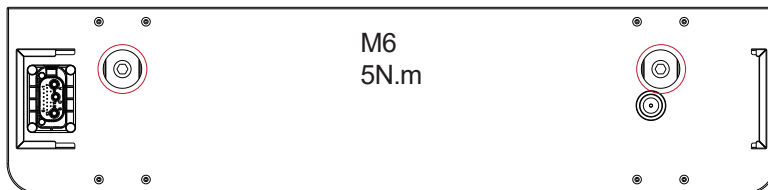

Installing Battery and Power Control Unit

NOTICE

- The following describes how to install the battery expansion modules for a 20kWh model.
- The installation of battery for 5kWh, 10kWh and 15kWh models is the same. One battery expansion module is installed for a 5kWh model, two battery expansion modules are installed for a 10kWh model, three battery expansion modules are installed for a 15kWh model.

Installing the Battery and PCU

- Step 1: Align the first battery module with the support on the base support and tighten the four screws on both sides;
- Step 2: Secure the first battery module on the wall.;
- Step 3: Install the remaining battery modules from bottom to top. After installing one battery, secure this battery on the wall, and then install the next battery.
- Step 4: Secure the PCU on the battery. Tighten the four screws on both sides.

1 Align the first battery module with the support on the base support.

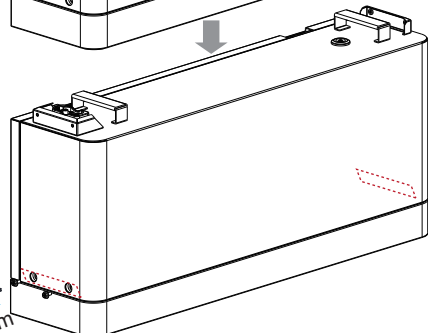
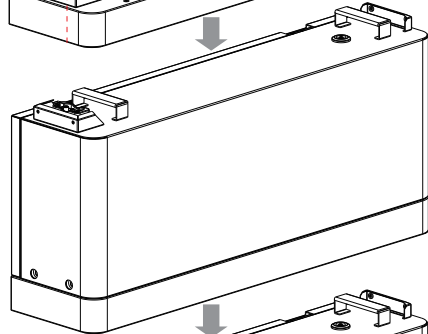
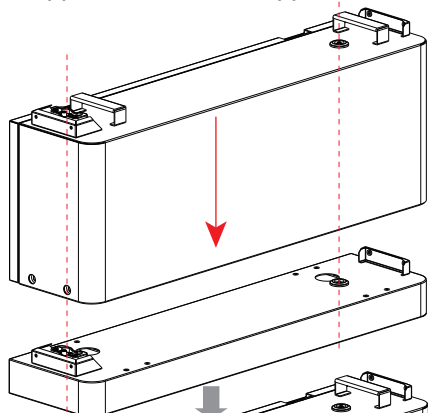

1.2N.m

Tighten the four screws on both sides

2 Secure the first battery module on the wall.

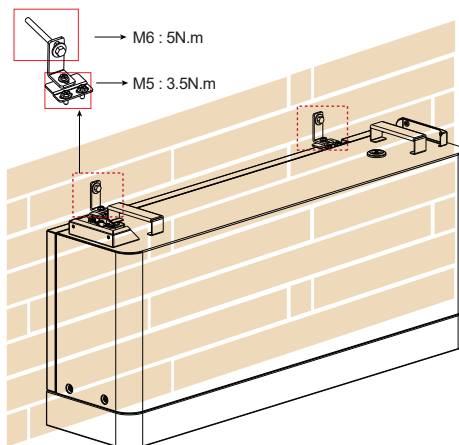
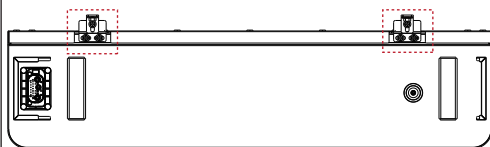

You can adjust the two connecting pieces vertically to align with the screw holes.

NOTICE

You need to secure the left and right screws on both sides first.

3

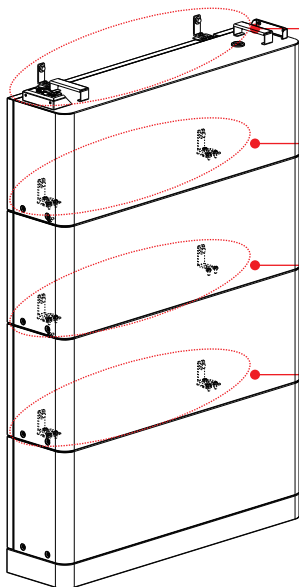

NOTICE

The top battery module must be secured to the wall.

Secure the battery modules in the middle to the wall.(Optional)

NOTICE

If base support cannot be secured on the ground, every battery module must be secured on the wall.

Install the remaining battery modules from bottom to top. After installing one battery, secure this battery on the wall, and then install the next battery.

4

Secure the PCU on the battery

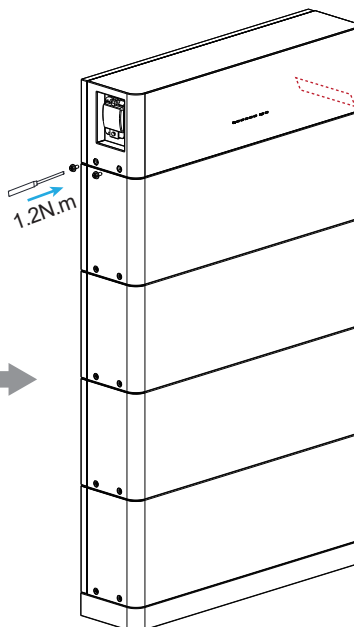
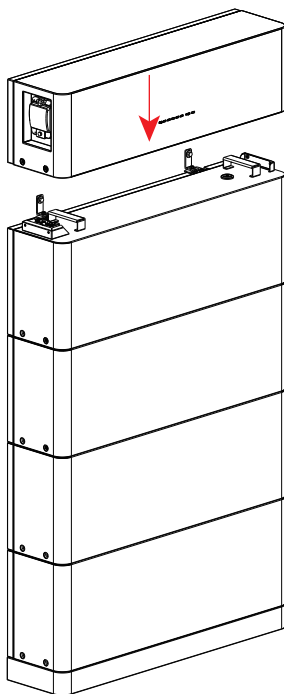

Tighten the four screws on both sides

4 Electrical Connection

4.1 Safety Precaution

DANGER

- The battery system exists high voltage during the equipment running. Please keep Power Off before any operations to avoid danger. Strictly follow all safety precautions outlined in this manual and safety labels on the equipment during the operation.
- All operations, cables and parts specification during the electrical connection shall be in compliance with local laws and regulations.
- Tie the same type cables together, and place them separately from cables of different types. Do not place the cables entangled or crossed.
- Make sure that the cable conductor is in full contact with the terminal and the cable insulation part is not crimped with the terminal when crimping the terminal. Otherwise, the device may not be able to work properly, or the connection may be unreliable during working, which may cause terminal block damage, etc.

NOTICE

- Wear personal protective equipment like safety shoes, safety gloves, and insulating gloves during electrical connections.
- All electrical connections should be performed by qualified professionals.
- Cable colors in this document are for reference only. The cable specifications shall meet local laws and regulations.

4.2 Electrical Connection

NOTICE

- A max of 2 battery systems can be parallel connected in one energy storage system. Ensure that the usable energy of each battery system is the same.

Single system:

1. Connect the power line "+" and "-" of the battery system to the "battery" port of the inverter;
2. Connect the communication RJ45 crystal head to the "CAN" port of the battery system, which is connected to the direct inverter;

Parallel system:

1. Connect the power line "+" and "-" of battery system 1 to the "battery 1" port of the inverter, and the power line "+" and "-" of battery system 2 to the "battery 2" port of the inverter;
2. Connect the RJ45 connector to the "CAN" port of battery system 1, which is connected to the direct inverter;
3. Connect the RJ45 LINK of battery system1 to the COM port of battery system 2.

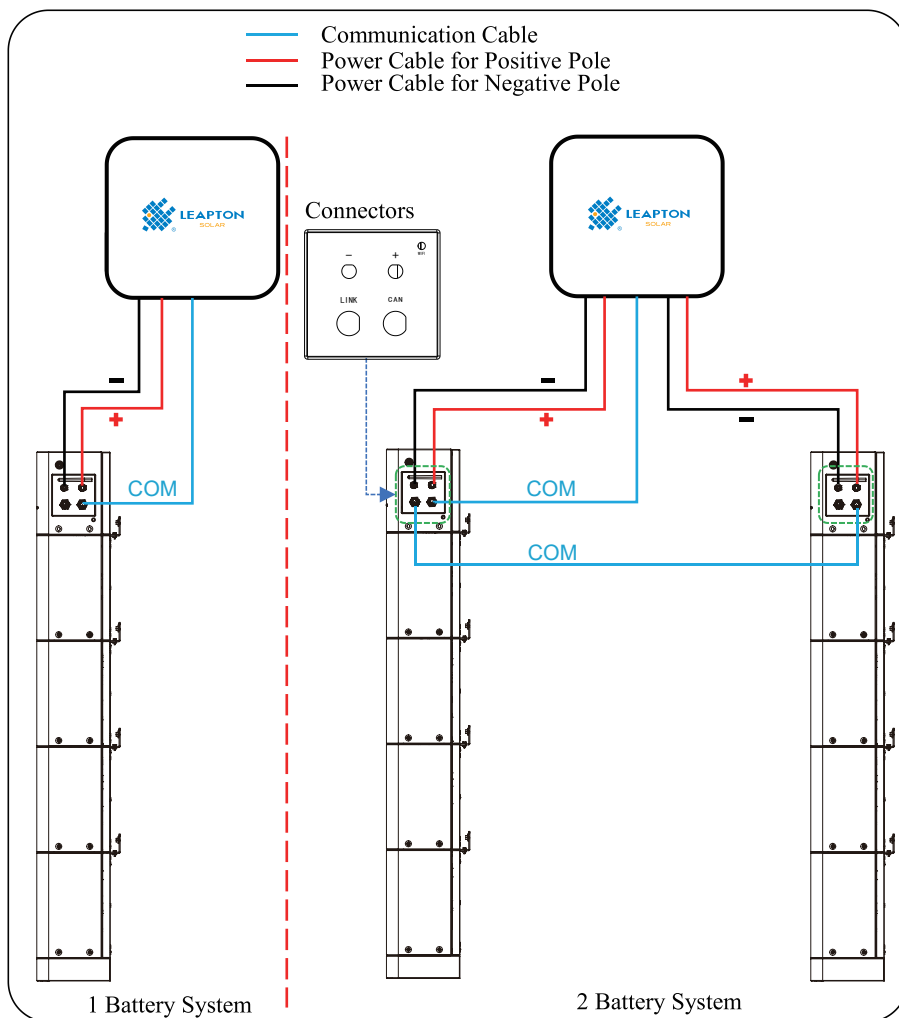

4.3 Connecting the PE cable

Connect the PE cable first before installing the equipment. Disconnect the PE cable before dismantling the equipment.

- The drawing force of the cable after crimping should be at least 400N.
- Connect the PE cable to the PCU.

If the PE cable in the deliverables cannot match the installation environment. The PE cable can be prepared by the customer. Recommended specifications:

- Type: single-core outdoor copper cable.
- Cross-sectional area: 4-6mm².

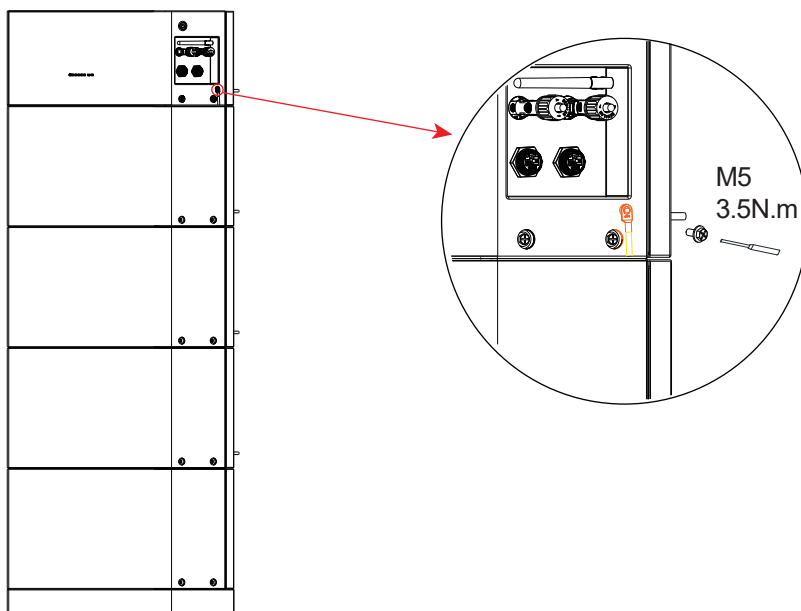
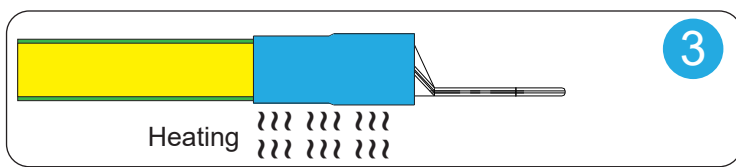
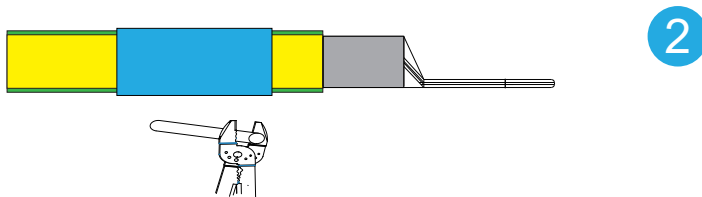
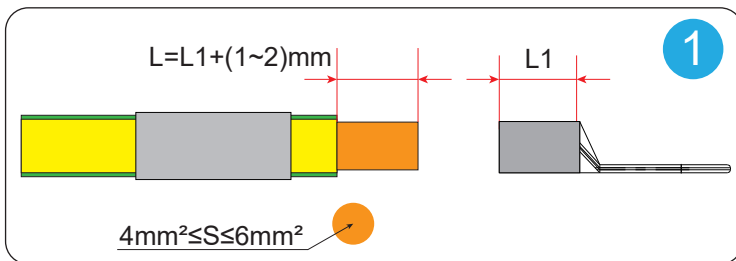

4.4 Connecting the Communication Cable

NOTICE

- The two communication ports of the battery are LINK and CAN.
- For one battery system, connect the cable to CAN port. And connect the other end of the cable to PCS.
- Please refer to the following pin definitions if you need to make a new battery communication cable.

RJ45 Connector

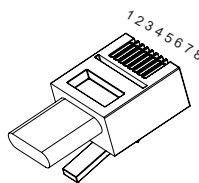
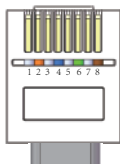

PIN	CAN	LINK	Description
1	CAN_GND2	CAN_GND2	BMS communication for battery system parallel connection
2	Addr_IN	Addr_OUT	
3	CANH2	CANH2	
4	CAN3H	/	Connects to the invert BMS communication port to communication with the invert
5	CAN3L	/	
6	CANL2	CANL2	BMS communication for battery system parallel connection
7	/	/	/
8	/	/	/

Step 1: Disassemble the communication connector.



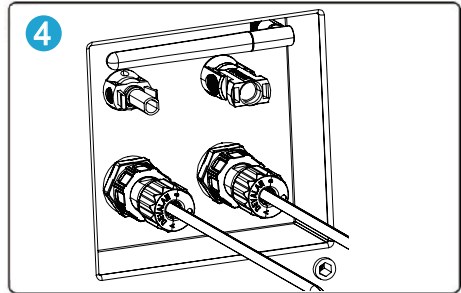
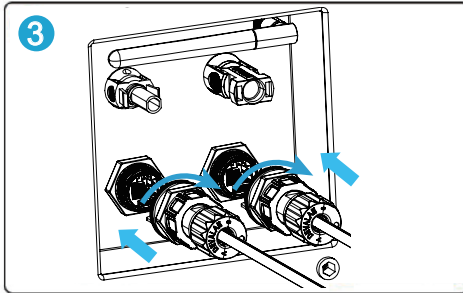
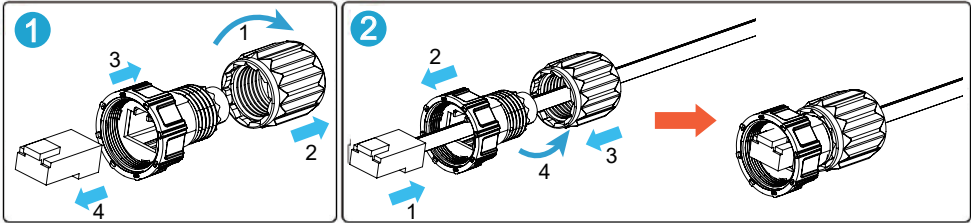

Step 2: Run the communication cable through the connector.

Step 3: Connect the communication cable to the battery. Tighten the connector.

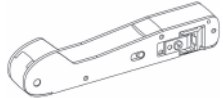

4.5 Connecting the Power Cable

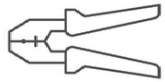
Tools:

Crimp tool for cold forming contact (for 10mm ² contact)	
Crimping die for cold forming contact (for 10mm ² contact)	
Strip tool for 6mm ² PV cable	
Wrench tool for D4 Cable connector	
Open-end back cap spanner for D4	

NOTICE

Power off the battery system before connecting the power cable to avoid high voltage danger.

- The DC input cable should be prepared by customers. Connect the positive connector to the red wire harness. And the negative connector to the black wire harness. The cable should meet standards for outdoor use.
- Install the back cover properly and make sure there is no space.
- The unused ports shall be protected using a cover.

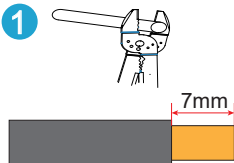

Strip the insulating layer of cable. $L=7\pm 0.5\text{mm}$; $S=10\text{mm}^2$; Be attention and not to cut off the wire core.

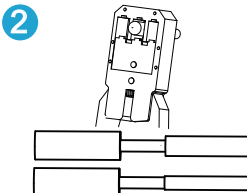

Rivet terminal . Ensure the concentricity of metal parts and cable at same level, crimped metal parts and cable pull tension $\geq 310\text{N}$.

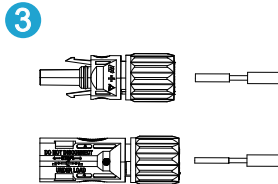

Push the riveted pin into the insulator until they engage. Pull lightly on the lead to check that the metal part has engaged.

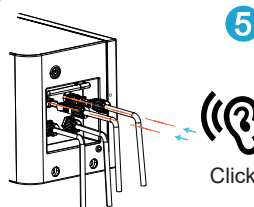
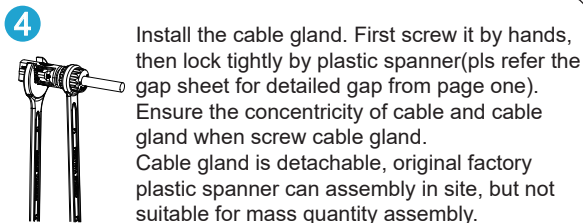

4.6 Verifying the Installation

NO.	Acceptance
1	The battery is installed correctly and securely.
2	The cables are routed properly as required by the customer.
3	Cable ties are secured evenly and no burr exists.
4	The ground cable is connected correctly and securely.
5	The battery switch and all switches connected to the battery are OFF.
6	The DC input power cables and signal cables are connected correctly and securely.
7	Idle terminals and ports are locked by watertight caps.
8	The installation space is proper, and the installation environment is clean and tidy.

DANGER

- Connect cables in accordance with local installation laws and regulations.
- Before connecting cables, ensure that the air switch on the PCU is set to OFF. Otherwise, the high voltage of the battery may result in electric shocks.

5 System Operation

Check the following items before power on to avoid the battery system being damaged.

Table 5.1: Check Item before Power On

NO.	Check Item
1	The inverter is firmly installed in a clean place where is well-ventilated and easy to operate.
2	The PE cable, power cable, communication cable are connected correctly and securely.
3	Cable ties are intact, routed properly and evenly.
4	Unused ports and terminals are sealed.

5.1 Battery System ON and OFF

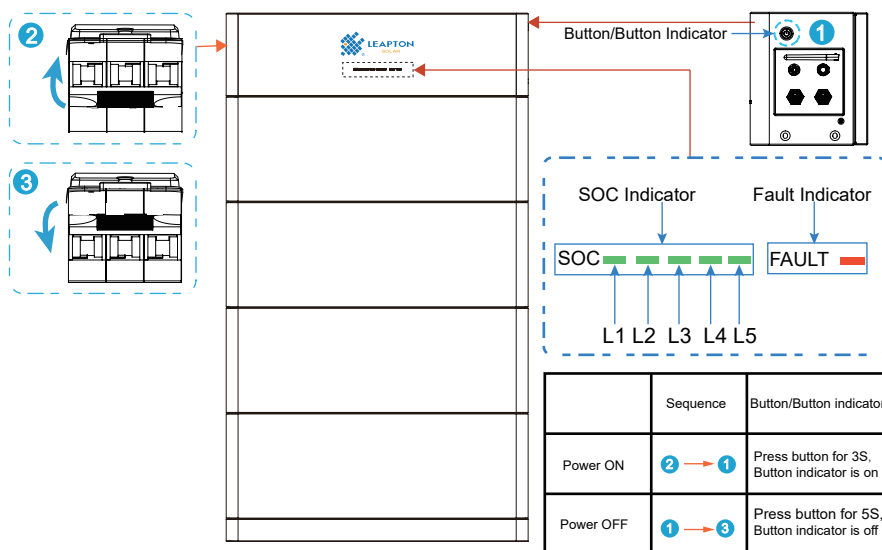

5.2 Indicator Status

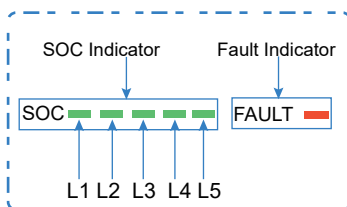

Table 5.2: LED Indicator

Type	SOC Indicator	Button Indicator	Fault Indicator	Meaning
Running indication	SOC ■ ■ ■ ■ ■	Steady Green	FAULT ■	Power on
	SOC ■ ■ ■ ■ ■	OFF	FAULT ■	Power off
	According to the fault referring to the Table 6.2	Steady Green	Steady red	Battery system alarm
	According to the SOC, Steady green	Steady Green	Blinking red	Communication Fault between battery system and PCS
SOC Indicator	SOC ■ ■ ■ ■ ■ ■	$\leq 10\%$ SOC, Blinking Green	FAULT ■	0~20% SOC
		$10\% < \text{SOC} \leq 20\%$, Steady Green		
	SOC ■ ■ ■ ■ ■ ■ ■	Steady Green	FAULT ■	20~40% SOC
	SOC ■ ■ ■ ■ ■ ■ ■ ■	Steady Green	FAULT ■	40~60% SOC
	SOC ■ ■ ■ ■ ■ ■ ■ ■ ■	Steady Green	FAULT ■	60~80% SOC
SOC ■ ■ ■ ■ ■	Steady Green	FAULT ■	80~100% SOC	

Note: If you do not operate the battery system for more than 5 minutes, the SOC indicator will automatically turn off and when you click the button, the SOC indicator will come back.

5.3 Battery Commissioning

5.3.1 Brief Introduction

This section gives a brief introduction to the main functions of "Leaptonair" APP account registration, plant creation, Wi-Fi configuration etc. Provide reference and help for users to quickly familiarize themselves with the APP.

It is suitable for E-LINTER users, pattern vendors and device maintenance personnel who use our device.

5.3.2 Download and Install the App

NOTE

- Supported mobile phone operating system: Android 5.0, iOS 11.0, or later versions
- To ensure the stability of each function, you are advised to use mobile phones running Android 8.0, iOS 13.0,

- or later versions. (For the mobile phones running iOS, iPhone 6 and later versions are supported, but iPhone SE is not supported.)

- The mobile phone supports the access to the Internet over a web browser.

Method 1

- iPhone users: search for “leaptonair” in the app store
- Android users: search “leaptonair” in the Google play store.

Method 2

iPhone & Android: Scan the QR code to download install the app.



Scan QR to Download App

Method 3

Visit <https://leapton.inteless.com> using a browser on your mobile phone to download and install the app.

5.3.3 Account Registration

5.3.3.1 Account registration

Users who use "Leaptonair" for the first time need to register an account, click "Register Account" on [Login Page] to enter the registration page.

Account" on [Login Page] to enter the registration page.

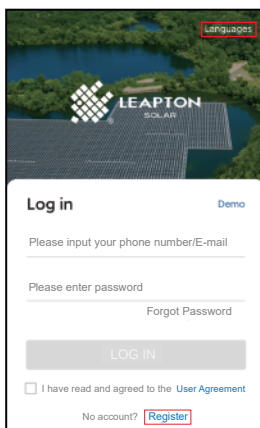

The screenshot shows the Leapton Solar app's login interface. At the top, there is a "Languages" button. Below it is the Leapton Solar logo and a background image of a solar panel array. The main section is titled "Log in" with a "Demo" link. It contains two input fields: "Please input your phone number/E-mail" and "Please enter password". Below the password field is a "Forgot Password" link. A "LOG IN" button is positioned below the input fields. At the bottom, there is a checkbox for "I have read and agreed to the User Agreement" and a "No account? Register" link.

5.3.3.2 Fill the information

Enter a valid phone number or email address to receive the verification code. After completing the registration information, check the box in the user agreement to indicate that you have read and agree to the agreement.

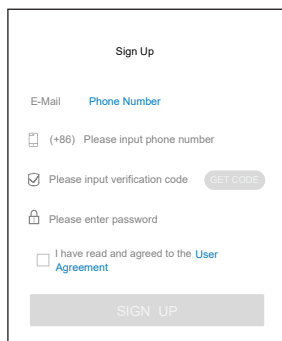

Sign Up

E-Mail **Phone Number**

Please input verification code

I have read and agreed to the [User Agreement](#)

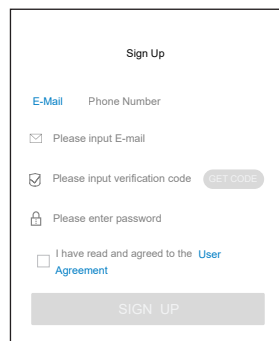

Sign Up

E-Mail Phone Number

Please input verification code

I have read and agreed to the [User Agreement](#)

NOTICE

If you do not receive the verification code, check whether the email address is correct, whether the network is abnormal, and whether the verification code has been sent to the spam mailbox.

5.3.4 Password Recovery

5.3.4.1 Enter forgot password

Click "Forget Password" at the lower right corner of the login window to enter the [Recover Password] page.

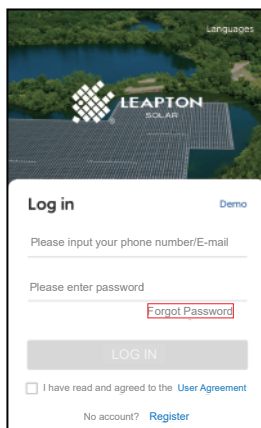

Log in Demo

Please input your phone number/E-mail

Please enter password

[Forgot Password](#)

I have read and agreed to the [User Agreement](#)

No account? [Register](#)

5.3.4.2 Forgot password

After completing the information on the [Retrieve Password] page, you can reset the new password.

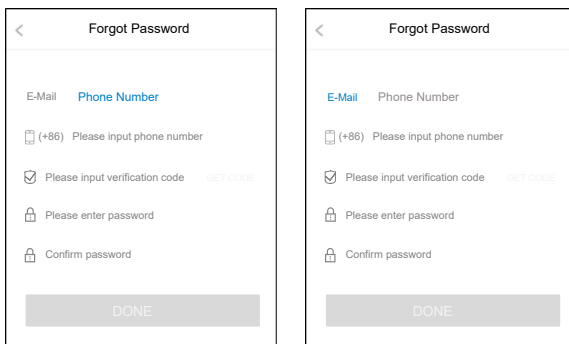

SIGN UP

NOTICE

If your mobile phone number or email is disabled or you cannot receive the verification code, please contact

5.3.5 Creat Plant

After logging in to PV-Pro, you can create your own power station and monitor the power station operating status and power generation data in real time.

5.3.5.1 Add device

Step 1

Go to the [Plants] page, click the "Create Plant" button to enter the [Create Plant] page.

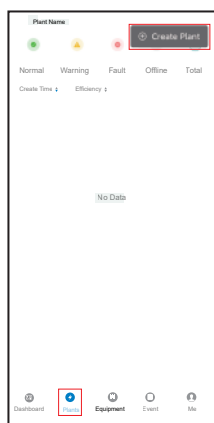

Step 2

After entering the scan code interface, you can use "scan QR code" or manually enter the devices "serial number" and "Key" code to add equipment.

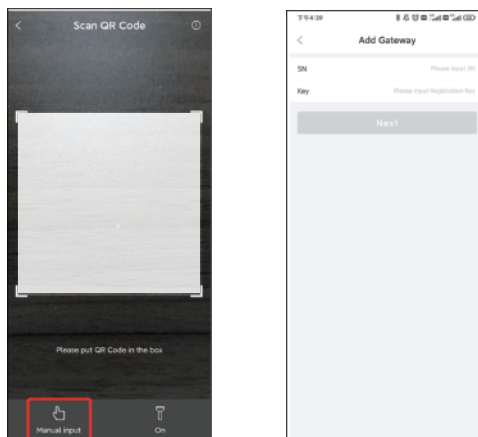

NOTICE

Please check the serial number and Key code of the device on the product label of the battery system. You can get the SN and Key on the top of the PCU.

5.3.5.2 Enter plant information

- 1) Entering a plant name that complies with the specification;
- 2) Enter the correct installed capacity;
- 3) Select the correct grid connection date;
- 4) When selecting an address, make sure that the power station address is correct (if you need to modify it, please click on the map to select it manually);
- 5) Confirm the time zone where the power station is located (incorrect time zone may cause abnormal statistics);
- 6) Choose the correct currency;
- 7) Choose the correct pricing method;
- 8) Enter the name of the person in charge of the plant;
- 9) Enter the correct plant contact phone number;
- 10) Enter the correct plant contact e-mail;
- 11) After making sure the information is correct, click "Create".

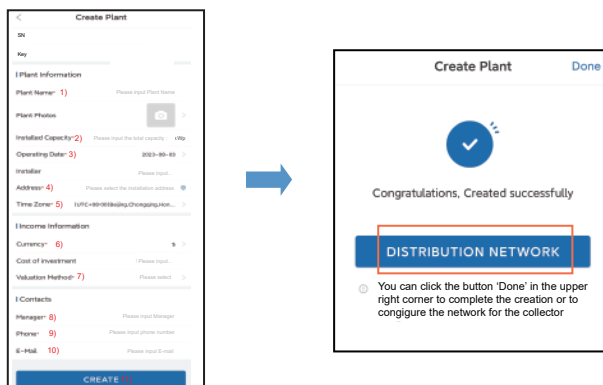

You can click the "Done" button in the upper right corner to complete the creation, or click "DISTRIBUTION NETWORK" to configure the collector network, or you can directly go to the personal center and select the "Tools" to configure the network for the collector.

5.3.6 Collector Network

If you select the method of "Scan the QR code of the device" to connect to the battery system, the steps are as follows.

5.3.6.1 Equipment network

1) Connect the collector with QR code:

If you select the method of "Scan the QR code of the device" to connect to the collector, the steps are as follows.

Step 1

Click the "Me" button at the bottom and select "Tools" from the menu.

Step 2

Enter the tool interface and select "Wi-Fi configuration".

Step 3

Select "Scan QR Code"

Step 4

"Scan the QR code on your device"

Step 5

After jumping to this page, the wireless LAN starting with "EBP-" will be automatically connected.

Step 6

If the connection fails,click"Reconnect" later, and it will jump to the "Connect Router" interface after the connection is successful.

Step 7

Click SSID to select the network.

Step 8

Connect to a WIFI with normal Internet access.

Step 9

After confirming that the router password is entered correctly, click the "confirm" button.

Equipment network-Connect the collector with QR

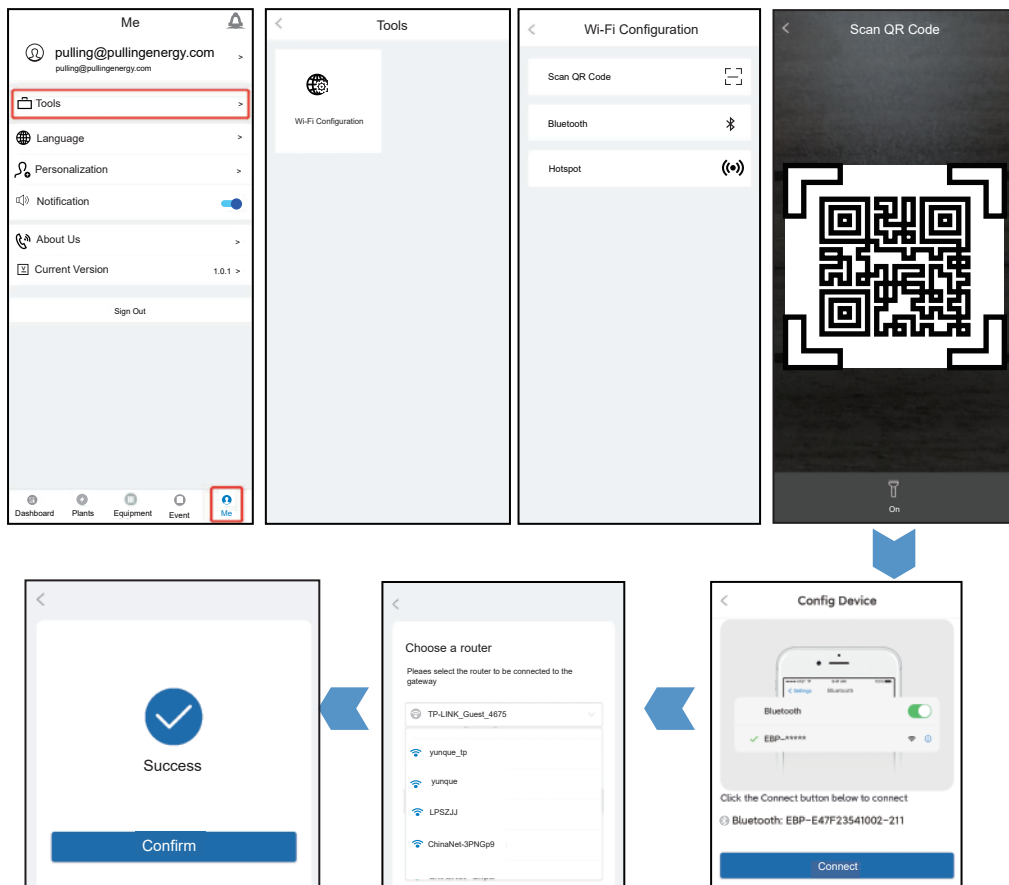

2) Connect the collector with bluetooth:

When selecting “Bluetooth” to connect the collector, the operation steps are as follows:

Step 1

Select “Bluetooth”

Step 2

First check the radio box with the prompt content "Check to confirm that the above conditions are met " and then click the "Connect" button.

Step 3

The APP will search for Wi-Fi devices that can be configured around and list them as a list, please select a network starting with EA4P." and the last 5 digits of the device serial number.

Step 4

If prompted for a password, the password is 12345678

Step 5

Select the router to connect to the gate way. Enter the router password and click the "confirm" button.

Step 6

Waiting for connection

Step 7

when the page jumps to the connection "Success", click the"Confirm" button to return to the home page

NOTICE

Prerequisites: Wi-Fi and location services must be enabled in advance. Please ensure that the device is powered on. When the device is powered on, the LED lights around the device must be on.

Equipment network-Connect the collector with bluetooth

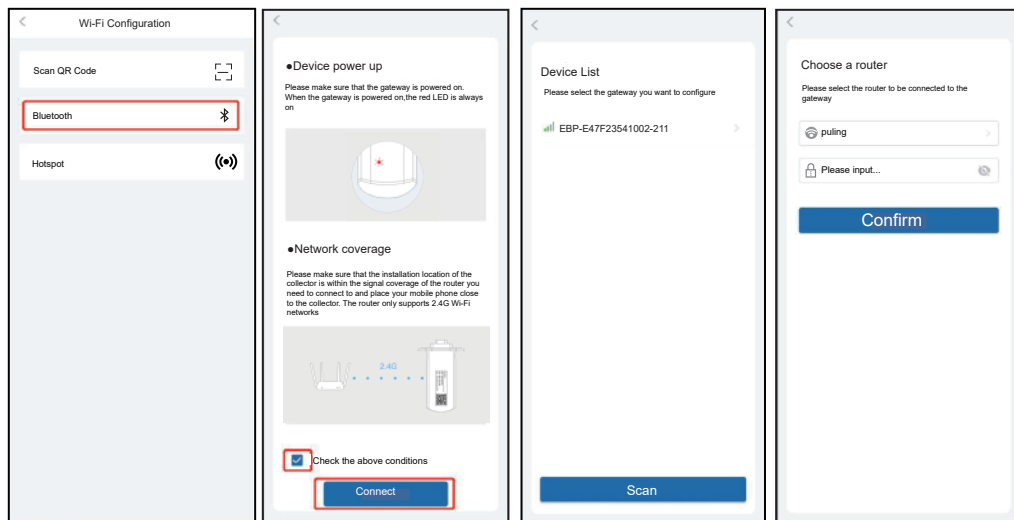

Wi-Fi Configuration

Scan QR Code 

Bluetooth 

Hotspot 

Device power up

Please make sure that the gateway is powered on. When the gateway is powered on, the red LED is always on.



Network coverage

Please make sure that the installation location of the collector is within the signal coverage of the router you need to connect to and place your mobile phone close to the collector. The router only supports 2.4G Wi-Fi networks.



Check the above conditions

Connect

Device List

Please select the gateway you want to configure

 EBP-E47F23541002-211

Scan

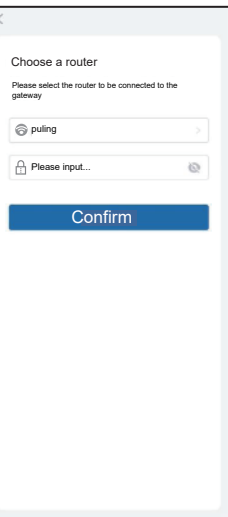

Choose a router

Please select the router to be connected to the gateway

 puling

 Please input...

Confirm

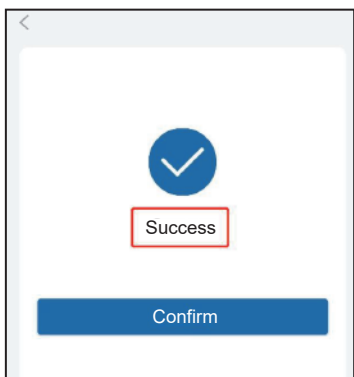



Success

Confirm

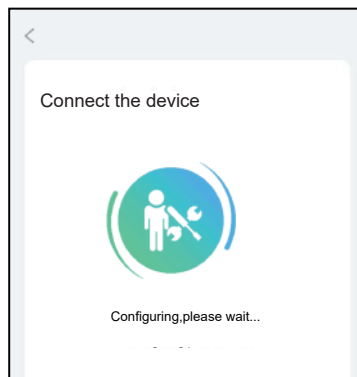

Connect the device



Configuring, please wait...

5.3.7 Plant Management

If you need to check the current status, equipment, and abnormal information of a power station, the specific operations are as follows:

5.3.7.1 Enter plant overview

Step 1

Select the power station you want to view in [Power Station list] ,and click the corresponding power station name to enter the power station **【Overview】** page.

"Energy Flow Diagram".

"Use for Power Generation".

"Generation Chart".

weather Information" and "Environmental Benefits"

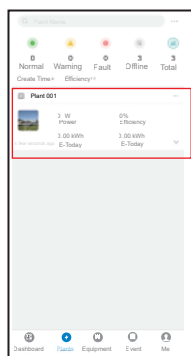

6 System Maintenance

6.1 Power OFF the Battery System

DANGER

- Power off the battery system before operations and maintenance. Otherwise, the equipment may be damaged or electric shocks may occur.
- Push the air switch to restart the battery.

Follow the steps below to power off the battery system to prevent the system from being damaged.

Method one:

Step 1: Turn off the inverter in the system following the instructions in the user manual of the inverter.

Step 2: Long press the multifunction button indicator for more than 5s, and make sure that the SOC indicator and button indicator of the PCU are off.

Method two:

Step 1: Turn off the inverter in the system following the instructions in the user manual of the inverter.

Step 2: Disconnect the air switch, and make sure that the SOC indicator and button indicator of the PCU are off.

6.2 Routing Maintenance

WARNING















- Contact after-sales service for help if you find any problems that may influence the battery or the hybrid inverter. Disassemble without permission is strictly forbidden.
- Contact after-sale service for help if the copper conductor is exposed. Do not touch or disassemble privately because the high voltage danger exists.
- In case of other emergencies, contact after-sales service as soon as possible. Operate following the instructions or wait for the after-sales service personnel.

Table 6.1: Maintaining Item

Maintaining Item	Maintaining Period
Check whether the locking brackets are secured, tighten it if not.	Once every 6 month
Check whether the outer enclosure is broken. Repair the painting or contact after-sales service if there is any broken.	Once every 6 month
Check whether there is an exposed cable. Replace the exposed cable or contact the after-sales service for help.	Once every 6 month
Check whether there is any dust around the battery module. Clean the dust if there is any to avoid affecting heat dissipation.	Once every 6 month
Check whether there is any liquid or pest near the battery to avoid intrusion in a long term.	Once every 6 month

6.3 Troubleshooting

Table 6.2: Maintaining Item

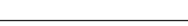
SOC Indicator		Fault Indicator	Fault Type	Solutions
1	SOC 	Steady red	Cell Fault	please contact the after-sales service
2	SOC 		Temp. Sensor Fault	Restart the battery. If the problem persists, please contact the after-sales service.
3	SOC 		Precharge Fault	Restart the battery. If the problem persists, please contact the after-sales service.
4	SOC 		Shortage	Power off and contact the after-sales service.
5	SOC 		Discharging Relay Fault	Restart the battery. If the problem persists, please contact the after-sales service.
6	SOC 		End of the Battery Life	Restart the battery. If the problem persists, please contact the after-sales service.
7	SOC 		Precharge Relay Failure	Restart the battery. If the problem persists, please contact the after-sales service.
8	SOC 		Cell Overvoltage Charging	Power off and wait for 2 hours. If the problem persists, please contact the after-sales service.
9	SOC 		Battery Overvoltage Charging	Power off and wait for 2 hours. If the problem persists, please contact the after-sales service.
10	SOC 		Overcurrent Charging	Restart the battery. If the problem persists, please contact the after-sales service.
11	SOC 		Cell Undervoltage DisCharging	Restart the battery. If the problem persists, please contact the after-sales service.
12	SOC 		Battery Undervoltage DisCharging	Restart the battery. If the problem persists, please contact the after-sales service.
13	SOC 		Overcurrent Discharging	Restart the battery. If the problem persists, please contact the after-sales service.
14	SOC 		High Temperature Charging	Restart the battery. If the problem persists, please contact the after-sales service.
15	SOC 		High Temperature/Low Temperature DisCharging	Power off and wait for 2 hours. If the problem persists, please contact the after-sales service.
16	SOC 		Charging&Discharging without Communication Between Battery System and PCS.	Power off and check the communication between battery system and PCS . Restart the battery, If the problem persists, please contact the after-sales service.
According to SOC		Bliking red	Communication Fault between battery system and PCS	Power off and check the communication between battery system and PCS . Restart the battery, If the problem persists, please contact the after-sales service.
Others				Contact the after-sales service.

6.4 Battery Storage and Recharge

6.4.1 Battery Acceptance Inspection

The battery production label must be put on the battery packing case.

6.4.2 Battery Storage Requirements

1. Place batteries according to the signs on the packing case during storage. Do not put batteries upside down or sidelong.
2. Stack battery packing cases by complying with the stacking requirements on the external package.
3. Handle batteries with caution to avoid damage.
4. The storage environment requirements are as follows:
 - Ambient temperature: $-10\text{--}55^{\circ}\text{C}$; recommended storage temperature: $20\text{--}30^{\circ}\text{C}$
 - Relative humidity: 5% to 80%
 - Place batteries in a dry and clean place with proper ventilation.
 - Place batteries in a place that is away from corrosive organic solvents and gases.
 - Keep batteries away from direct sunlight.
 - Keep batteries at least 2 meters away from heat sources.
5. The batteries in storage must be disconnected from external devices. The indicators (if any) on the batteries should be off.
6. AC mains input voltage requirements in the recharge places: single-phase power grid: 220 V/230 V/240 V, $\pm 10\%$; three-phase voltage: 380 V/400 V, $\pm 10\%$.
7. The warehouse keeper should collect battery storage information every month and periodically report the battery inventory information to the planning department. The batteries that have been stored for nearly 12 months ($-10\text{--}25^{\circ}\text{C}$), 6 months ($25\text{--}35^{\circ}\text{C}$) or 3 months ($35\text{--}55^{\circ}\text{C}$) should be recharged in a timely manner
8. Batteries should be delivered based on the "first in, first out" rule.
9. After the battery production test is complete and before the batteries are stored, the batteries must be recharged to at least 50% of the SOC.

6.4.3 Conditions for Judging Overdue Storage

It is recommended that batteries not be stored for a long period. They should be used soon after being deployed onsite. The batteries should be handled according to the following requirements.

Required Storage Temperature	Actual Storage Temperature	Recharge Interval	Remarks
-10°C < T ≤ 55°C	T ≤ -10°C	Not allowed	Not reaching the time for recharge: Use the batteries as soon as possible. Reaching the time for recharge: Recharge the batteries. The total storage duration should not exceed the warranty period.
	-10°C < T ≤ 25°C	< 12 months	
	25°C < T ≤ 35°C	< 6 months	
	35°C < T ≤ 55°C	< 3 months	
	55°C < T	Not allowed	

1. Dispose of deformed, damaged, or leaking batteries directly irrespective of how long they have been stored.
2. The storage duration starts from the latest charge time labeled on the battery package. If a battery is qualified after recharge, update the latest charge time and the next recharge time (next recharge time = latest charge time + recharge interval) on the label.
3. If stored for more than 12 months (Calculated from battery production date) under the specified conditions, the battery needs to be charged once, until the system SOC is 30%. Preferably, use an hybrid inverter for forced charging
4. If a lithium battery is stored for a long time, capacity loss may occur. After a lithium battery is stored for 12 months in the recommended storage temperature, the irreversible capacity loss rate is 3%–10%. If customers perform the discharge test according to the specification, they may fail to pass the test if the storage capacity of the battery is not 100% of the rated capacity.

6.4.4 Inspection Before Recharge

1. Before recharging a battery, you need to check its appearance. Recharge the battery if it is qualified or dispose of it if not.
2. The battery is qualified if it is free from the following symptoms:
 - a) Deformation;
 - b) Shell damage;
 - c) Leakage.

6.4.5 Battery Recharging

Inverter or specified charger to charge the battery, support single battery recharge, do not allow two or more batteries to charge at the same time;

Networking diagram of the power-on scenario

- Communication Cable
- Power Cable for Positive Pole
- Power Cable for Negative Pole

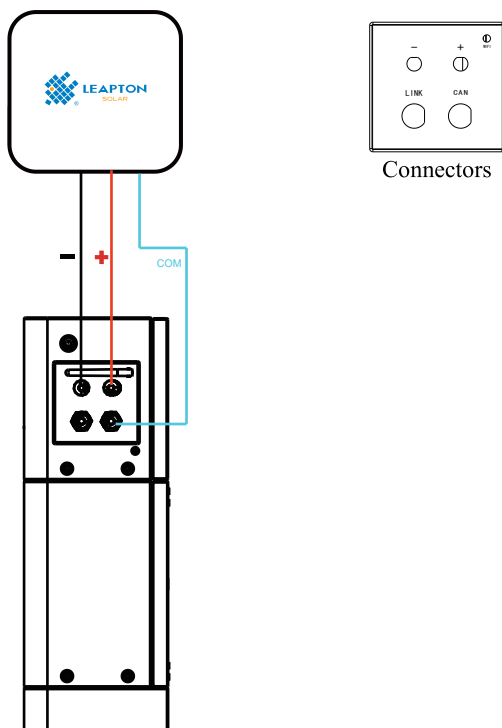

6.4.6 Battery Recharging Cable Connection

⚠ WARNING

Use standard cables provided by Lepton to connect the power control module and battery expansion modules. Do not use non-standard cables (such as extension cables and interconnection cables). If B+ or B- battery cables are reversely connected, the device will be damaged.

6.4.7 Battery Power-On and Commissioning

NOTICE

- Ensure that the charge process is supervised to prevent any abnormality.

- If a battery experiences an abnormality such as bulging or smoking, stop charging immediately and dispose of it.
- Ensure that only trained professionals perform recharge operations.
- After turning on the battery switch, power on the inverter. For details about how to power on the inverter, see the quick guide for the corresponding inverter model.
- It is recommended that the battery be charged to 50% SOC. Long-term storage will cause capacity loss, after a lithium battery is stored for 12 months in the recommended storage temperature, the irreversible capacity loss rate is 3%–10%.

Step 1 Connect power cables and communications cables correctly.

Step 2 Turn on the charging device, then turn on the circuit breaker of the battery system.

Step 3 Turn on the AC switch between the inverter and the grid.

Step 4 Hold down the start button for 15s (release the hand for the third time) to enter the power supply mode and activate the battery system.

Step 5 Connect the battery system using the LEAPTONAIR APP. For details, please refer to “5.3 Battery Commissioning”.

Step 6 Confirm that the recharge is complete if five indicators of the ring LED are on and steady green.

Step 7 After the battery is charged, switch off the inverter input AC and then the battery input circuit breaker. If other batteries need to be charged, repeat the preceding steps.

6.4.8 Storage with Low SOC

After the ESS is powered off, static power consumption and self-discharge loss may occur in battery modules. Therefore, charge battery modules in a timely manner and do not store the ESS in low state of charge (SOC). Otherwise, the ESS may be damaged due to overdischarge, and battery modules need to be replaced.

Storing the ESS with low SOC may occur in the following scenarios:

1. The energy storage circuit breaker is on but the button is OFF.
2. The battery power cable or signal cable is not connected and cannot be powered on.
3. The ESS cannot be charged due to a system fault after discharge.
4. The ESS cannot be charged due to incorrect configurations in the system.
5. The ESS cannot be charged due to no PV input and long-term mains failure.

Regardless of scenarios, the ESS must be charged within the maximum interval corresponding to the SOC when the ESS is powered off. If the ESS is not charged beyond the maximum interval, it may be damaged due to overdischarge.

Power-Off SOC Before Storage	Maximum Charge Interval
$SOC \geq 5\%$	30days
$0 \leq SOC < 5\%$	7days

Note

When the SOC of the ESS decreases to 0%, charge the ESS within seven days. Any permanent battery damage due to customer's failure to charge the ESS properly is not covered under warranty.

7 Parameters

Technical Data	EH-A05-102/102	EH-A05-102/204	EH-A05-102/307	EH-A05-102/409
Rated Energy(kWh)* 1	5.12	10.24	15.36	20.48
Usable Energy (kWh)* 1	4.6	9.2	13.8	18.4
Battery Module Energy	EHA05/5.12kWh			
Number of Modules	1	2	3	4
Cell Type	LFP (LiFePO ₄)			
Cell Configuration	32S1P	64S1P	96S1P	128S1P
Rated Capacity(Ah)	50			
Nominal Voltage (V)	102.4	204.8	307.2	409.6
Operating Voltage Range (V)	91.2~115.2	182.4 ~ 230.4	273.6 ~ 345.6	364.8 ~ 460.8
Recommend Charge/Discharge Current (A)	25			
Recommend Charge/Discharge Power (kW)	2.56	5.12	7.68	10.24
Max. Charging/Discharging Current (A)* 2	50			
Max. Charging/Discharging Power (kW) * 2	5.12	10.24	15.36	20.48
Weight (kg)	70	125	180	235
Dimensions (W × H × D mm)	800*560*195	800*840*195	800*1120*195	800*1400*195
Communication	CAN/RS485			
Operating Temperature (°C)	Charge: 0 ~ +55; Discharge: -20 ~ +55			
Operating Temperature (Recommended) (°C)	15~30			
Relative Humidity	5%~95%			
Environment	Outdoor / Indoor (*Please refer to the user manual for installation condition)			
Cooling	Natural convection			
Ingress Protection Rating	IP65			
Max. Operating Altitude (m)	2000			
Mounting Method	Floor stand			
Certificates	CE, IEC62619, UN38.3			

1、 Value for Battery Cell Only (Depth of Discharge 90%). Actual usable energy at the AC output may vary by condition, such as the battery converter, inverter efficiency and temperature.

2、 PULLING recommends 25A@2.5kW for maximum battery module lifetime.Max dis-/charge current and power derating will occur related to temperature and SOC.

Suzhou Leapton Energy Co., LTD
No. 9, Sunshine Avenue, Yushan High Technology Industry Zone, Changshu City, Jiangsu
Province, 215500 PR.China

FAX : 862-512-88800068 website : <https://www.leaptonpv.com>